

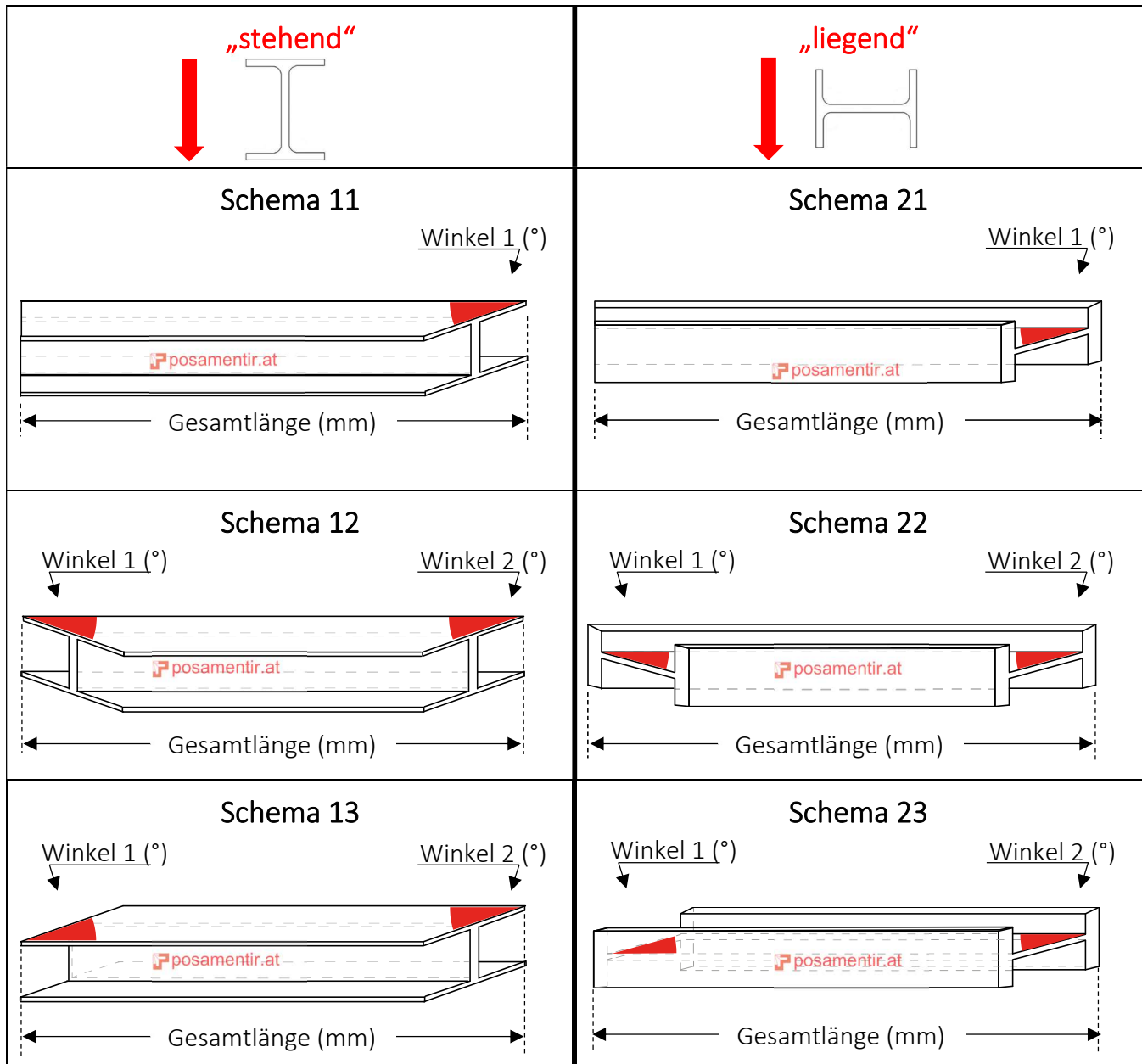

Schnittschema Gehrungsschnitte für Stahlträger

Schema H / I Träger (HEA / HEB / HEM / IPE / INP)

Winkel „“ mindestens 30°













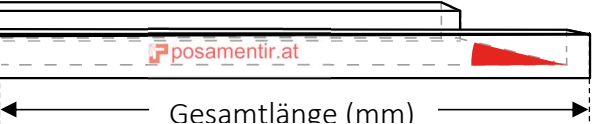

Schnittschema Gehrungsschnitte für Stahlträger

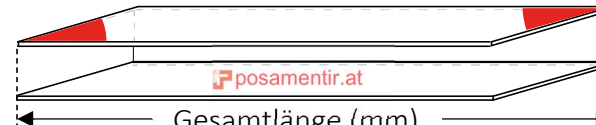
Schema U Träger (UNP / UPE)

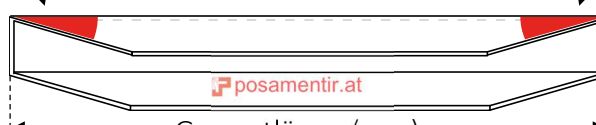
Winkel „“ mindestens 30°

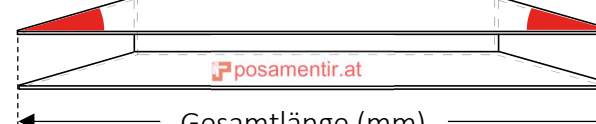
<p style="text-align: center;">„liegend“</p> 	<p style="text-align: center;">„stehend“</p> 
<p style="text-align: center;">Schema 51 Winkel 1 (°)</p> 	<p style="text-align: center;">Schema 61 Winkel 1 (°)</p> 
<p style="text-align: center;">Schema 52 Winkel 1 (°)</p> 	<p style="text-align: center;">Schema 62 Winkel 1 (°)</p> 
<p style="text-align: center;">Winkel 1 (°) Schema 53 Winkel 2 (°)</p> 	<p style="text-align: center;">Winkel 1 (°) Schema 63 Winkel 2 (°)</p> 
<p style="text-align: center;">Winkel 1 (°) Schema 54 Winkel 2 (°)</p> 	<p style="text-align: center;">Winkel 1 (°) Schema 64 Winkel 2 (°)</p> 
<p style="text-align: center;">Winkel 1 (°) Schema 55 Winkel 2 (°)</p> 	<p style="text-align: center;">Winkel 1 (°) Schema 65 Winkel 2 (°)</p> 



Schnittschema Gehrungsschnitte für Formrohre und Hohlprofile

Schema Formrohre / Hohlprofile QUADRATISCH

Winkel „“ mindestens 30°

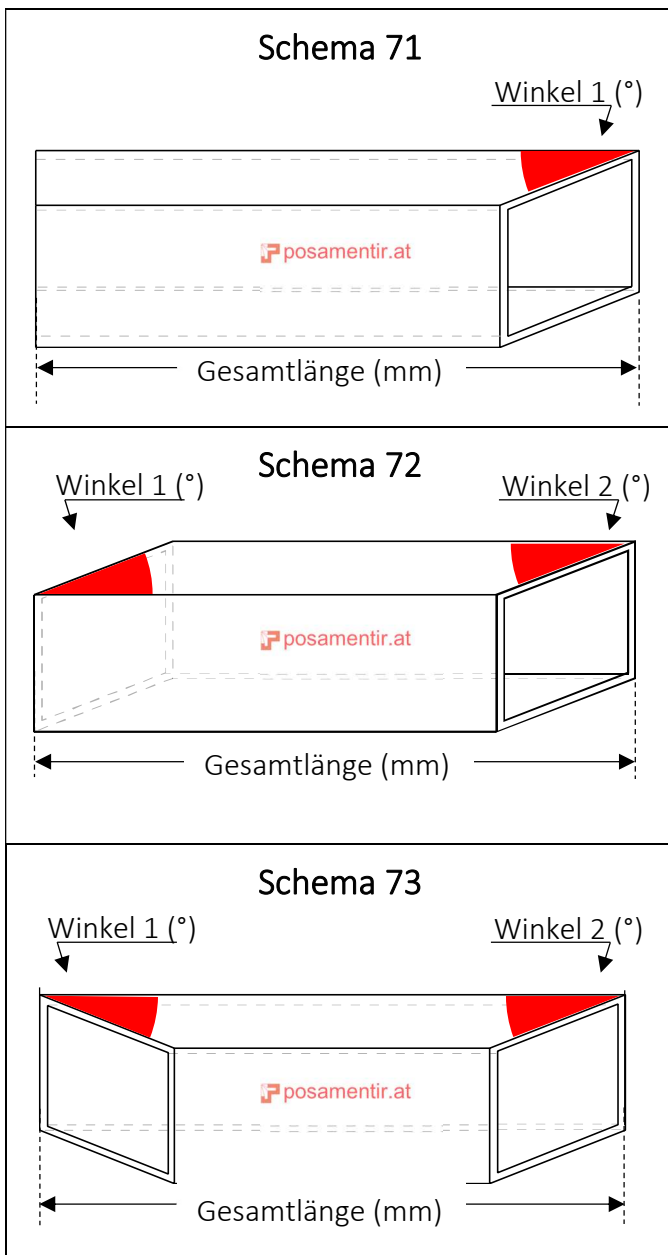



Schnittschema Gehrungsschnitte für Formrohre und Hohlprofile

Schema Formrohre / Hohlprofile RECHTECKIG

Winkel „ ◀ “ mindestens 30°

„liegend“

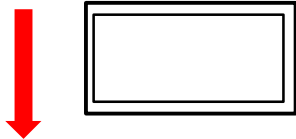

„stehend“

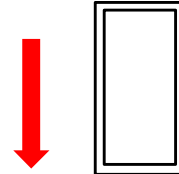

Schema 81

Winkel 1 (°)

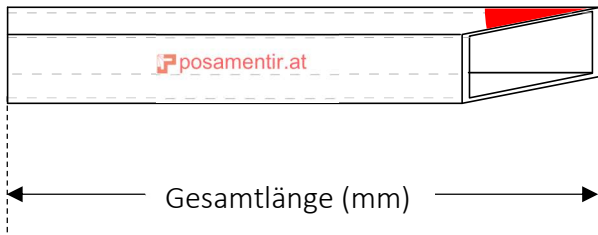

Schema 91

Winkel 1 (°)

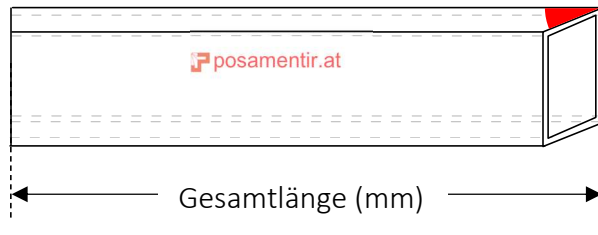

Schema 82

Winkel 1 (°)

Winkel 2 (°)

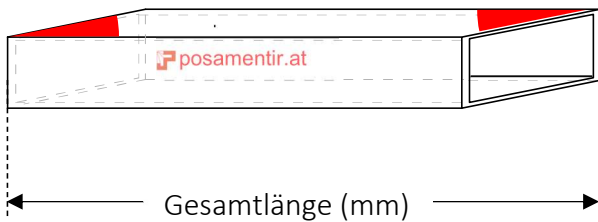

Schema 92

Winkel 1 (°)

Winkel 2 (°)

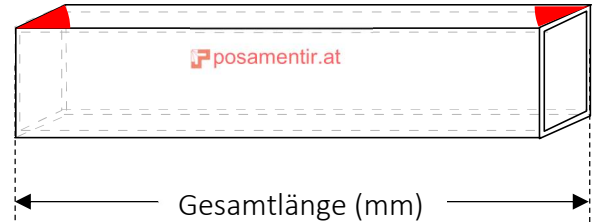

Schema 83

Winkel 1 (°)

Winkel 2 (°)

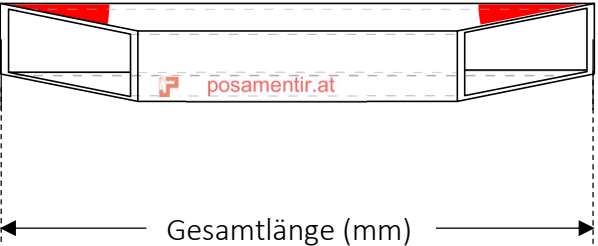

Schema 93

Winkel 1 (°)

Winkel 2 (°)

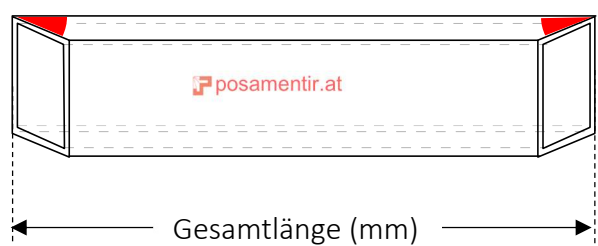



Zentrale 1230 Wien
Siebenhirtenstraße 15
+43 1 869 47 71 70
Info.zentrale@posamentir.at

www.posamentir.at

Stadtlager 1160 Wien
Koppstraße 7
+43 1 492 09 29
Info.stadtlager@posamentir.at

BESTELLUNG GEHRUNGSSCHNITTE

Hiermit beauftragen wir folgende Gehrungsschnitte laut Schema

Firmenwortlaut:

Datum:

Firmenmäßige Zeichnung:

Stk.	Profil	Länge (mm)	Schema	Winkel 1 nur ganze Grade min. 30°	Winkel 2 nur ganze Grade min. 30°